



INSTALLATION AND USE MANUAL



HEAT RECOVERY UNITS

KVMC25VL
KVMC25VLC
KVMC25VLH
KVMC25VLHC

KVMC25VLE
KVMC25VLCE
KVMC25VLHE
KVMC25VLHCE



VENTALOGIC

Ar puro Vida plena

INTRODUCTION AND PURPOSE OF THE MANUAL

In standard UNI EN ISO 12100:2010 the term “instructions for use “or“ instruction manual “means the sum of the means of communication, such as text, words, signs, symbols, diagrams or signals used separately or in combination to transfer instructions to the user.

The instructions for use are directed to professional users and / or non-professional users and are considered an integral part of the delivery of the machine.

With the Machinery Directive and the Liability Directive for a defective product instructions for use have assumed a critical importance for safety, they are no longer solely aimed at meeting the needs of the customer in terms of the proper use of the machine for production purposes but of fundamental importance for safety, and take a great importance in defining the limits of liability of the manufacturer.

The instructions for use shall take into account all the aspects related with the product and its use and that may involve health and safety issues such as: the life stages of the means of labor (packing, storage, installation, repair and demolition), the intended use and reasonably foreseeable use of the machine, the user's characteristics and residual risks present in the product. In order to achieve the goals of safety and in the more general to meet the requirements of clarity and readability of the documents containing the instructions for use has followed the provisions of UNI EN ISO 12100:2010. The Manual of heat recovery units BROFER has therefore been prepared in accordance with the above specifications.

**This machine is built in compliance with the EC Directives on safety
The following generic copy of the EC declaration of conformity**

**BROFER SRL
Via Roma, 66 - 31023 Resana (TV) Italy
Tel. +39 0423 716611 - Fax +39 0423 716612
www.brofer.it
info@brofer.it**



DECLARATION OF CONFORMITY

The BROFER S.r.l. declares that the heat recovery units KVMC25VL(E), KVMC25VLC(E), KVMC25VLHE) e KVMC25VLHC(E). It complies with Directive 2006/42/EC on the same applicable and relevant harmonized standards.

The person authorized to compile the technical file is the Legal Representative Mr. Brotto Gianluca available in BROFER located at the address below.

In particular, the analysis of the risk of the machine described, complies with the harmonized UNI EN ISO 12100:2010 and the following harmonized standards::

DIRECTIVE 2006/42/CE
DIRECTIVE 2014/35/UE Low Voltage
DIRECTIVE 2014/30/UE Electromagnetic Compatibility EMC

DECLARATION OF INCORPORATION (Annex 2, paragraph B DIRECTIVE 2006/42/EC)

The BROFER S.r.l. also states that the machine to which this declaration should not be placed in service before being incorporated into a machine, or system, in conformity with DIRECTIVE 2006/42/EC.

BROFER S.r.l
Legal rapp.te
Mr. Brotto Gianluca

Resana,

BROFER S.r.l. - Via Roma,66 - 31023 Resana (Tv)
Tel. 0423/716611 - Fax 0423/716612

INDEX

1. GENERAL INFORMATION	pag 4	14. CONFIGURATION CHANGE FROM A (STANDARD) TO B	16
2. GENERAL SAFETY	5	15. ELECTRICAL CONNECTIONS	18
3. LIFTING INSTRUCTIONS	5	16. HYDRAULIC CONNECTIONS	24
4. INSTALLATION INSTRUCTION	5	17. AERAUIC CONNECTIONS	24
5. INSTRUCTIONS FOR USE	5	18. VERIFICATION OF CURRENT CONSUMPTION	24
6. SAFETY INSTRUCTIONS FOR MAINTENANCE	5	19. OPERATION AND USE	24
7. STORAGE	5	20. ROUTINE MAINTENANCE	25
8. PROVISION	5	21. DEFROST PROTECTION	25
9. SCRAPPING	5	22. FREE-COOLING	25
10. GENERAL TECHNICAL DATA TABLE	6	23. CONTROL SYSTEM	26
11. IDENTIFICATION OF THE MACHINE	8	24. DEVICE ERROR MESSAGES	28
12. DECLARATION OF ENERGY PERFORMANCE	10	25. MAINTENANCE AND OPERATIONS	29
13. MODE OF INSTALLATION	12		

1. GENERAL INFORMATION

The heat recovery units series RDCD25SK(E), RDCD25SKC(E), RDCD25SKH(E) e RDCD25SKHC(E) must be installed and operated in accordance with the requirements contained in this manual. The strict observance of these simple and basic instructions is a prerequisite for: Eliminate or reduce downtime due to faults or unforeseen anomalies; Increasing the life of the components and the entire unit; Decrease the costs of maintenance. For technical data, installation methods and what concerns maintenance of the units with enthalpy exchanger, refer to the respective version with standard exchanger. From now on, the letter (E) of the enthalpy version is intentionally excluded from this manual.

MACHINE DOES NOT SUITABLE FOR WORK ENVIRONMENT IN WITH EXPLOSIVE ATMOSPHERE AND IN ENVIRONMENTS WITH HIGHLY CORROSIVE AGENTS.

COMPONENTS OF THE UNIT

(Valid for all units)

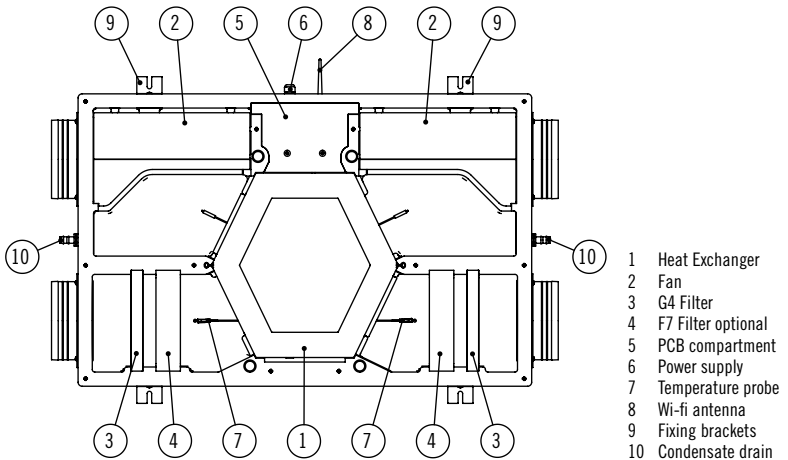

2. GENERAL SAFETY

The BROFER S.R.L. considers the safety and proper operation of the product only if the electrical system and the power of the place of installation complies with current regulations and if the product is installed and used according to the rules described below.

3. LIFTING INSTRUCTIONS

The load during both the charging and discharging, should always be lifted from the base of the product by means of a crane or forklift with adequate capacity to support the weight, do not turn it or place on the sides and submit to strong shock. The product is supplied with a suitable protective packaging that provides only shelter from dust and scratches the surface, it is advisable to protect it from the elements. Take all precautions required by safety regulations to avoid possible damage to persons or property.

4. INSTALLATION INSTRUCTIONS

The installation of the machine, as well as the appropriate electrical connections to ducts and fittings must be performed by skilled technicians in the industry. The machine also requires a space environment free of obstacles and enabling the smooth opening of the doors of inspection as well as enough space for the extraction of the filters and the electrical wiring of the fans. The following is possible modes of fixing of the heat recovery unit. We emphasize that the anchor points and the dimensioning of the brackets must be made from time to time in respect of the plant situation and dimensioning of the static and dynamic system.

5. INSTRUCTION FOR USE

Before operating the machine, make sure that the electrical connections are correctly wired and the condensate drain is specially connected, check to make sure no foreign objects have been left inside the machine and that any electrical cords are fixed adequately. Do not open the inspection doors with moving parts or introduce hands with the machine running, as indicated by appropriate pictograms.

6. SAFETY INSTRUCTIONS FOR MAINTENANCE

Before performing any maintenance make sure that the machine is disconnected from the power supply. The product is made in order to facilitate maintenance operations that allow it to be carried out by qualified personnel. Where were carried out repairs or extraordinary maintenance, please contact BROFER SRL that will have them done by authorized personnel or give consent to be able to be performed by other qualified personnel. For any other problem, doubt or anomaly before proceeding with operations that can be harmful to the machine or incorrect, contact the service office BROFER which will provide all the necessary information to be able to solve, if possible, the case.

7. STORAGE

Permitted storage of the machine for a long time as long as the place is dry, protected from the sun and at a temperature between 0 and 40 ° C, protected from rain and humidity, maybe suggest to keep the packaging intact and support the machine on pallets or shelves.

8. PROVISIONS

You cannot set aside the machine.

9. SCRAPPING

If you decide not to use this product it is recommended to disconnect the power supply, disassemble and dispose of all the various components of the item out of landfill in order to comply with the regulations in force in order to respect the environment.

10. GENERAL TECHNICAL DATA TABLE

	KVMC25VL	KVMC25VLH
Nominal air flow (mc/h)	180	250
Useful static pressure (pa)	100	100
DATA FOR EACH FAN		
Installed power (W)	27	50
Round (1/MIN)	3700	4320
Current (A)	0,27	0,46
Rated voltage (V)	230	230
Frequency (HZ)	50	50
Speed (nr)	1	1
FILTERS		
Efficiency Standard	G4	G4
Efficiency Optional	F7	F7

Valid for KVMC25VL and KVMC25VLH

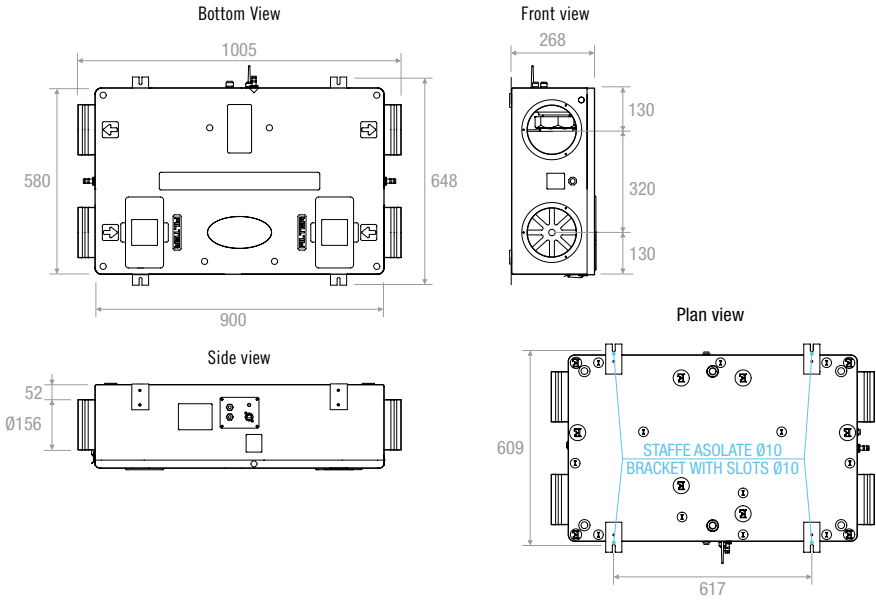

WEIGHT: 14 kg

	KVMC25VLC	KVMC25VLHC
Nominal air flow (mc/h)	180	250
Useful static pressure (pa)	100	100
DATA FOR EACH FAN		
Installed power (W)	27	50
Round (1/MIN)	3700	4320
Current (A)	0.27	0,46
Rated voltage (V)	230	230
Frequency (HZ)	50	50
Speed (nr)	1	1
FILTERS		
Efficiency Standard	G4	G4
Efficiency Optional	F7	F7

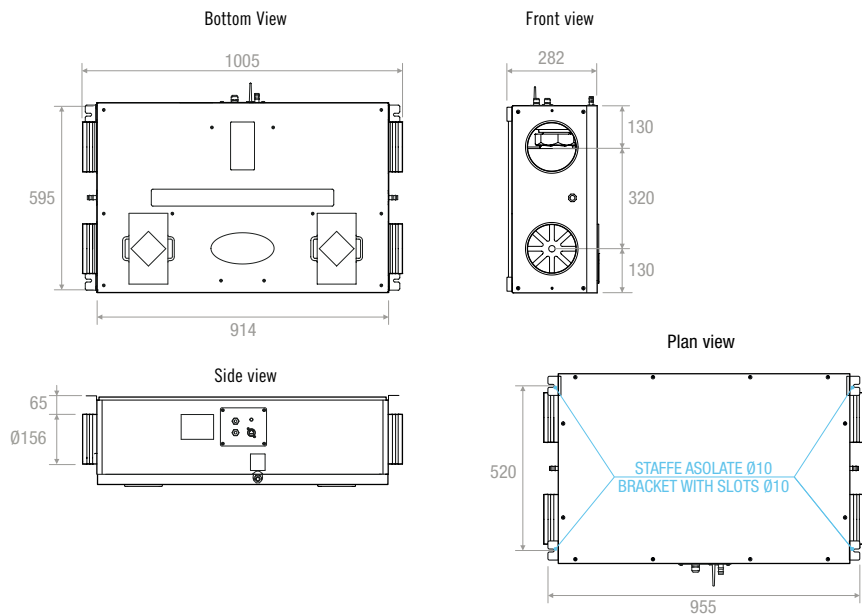

Valid for KVMC25VLC and KVMC25VLHC



WEIGHT: 30 kg

11. IDENTIFICATION OF THE MACHINE

Each unit is equipped with a identification plate that contains important data on the machine.

 VENTALOGIC	
	www.ventalogic.com
UNIT TYPE	<input type="text"/>
SERIES NUMBER	<input type="text"/>
FAN CODE	<input type="text"/>
POWER INPUT (KW)	<input type="text"/>
OPERATING CURRENT (A)	<input type="text"/>
POWER SUPPLY (V-F/PH - HZ)	<input type="text"/>

It is necessary for any relationship with the VENTALOGIC, always quote the type and / or serial number shown on this plate

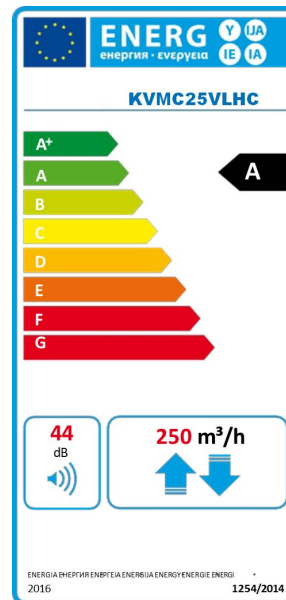
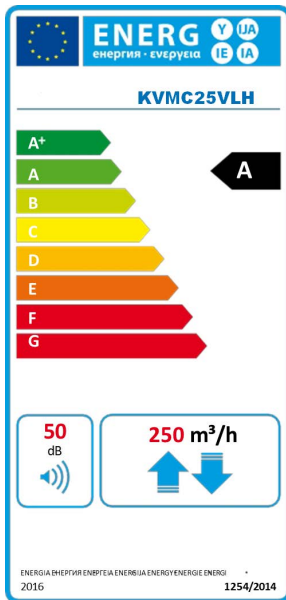
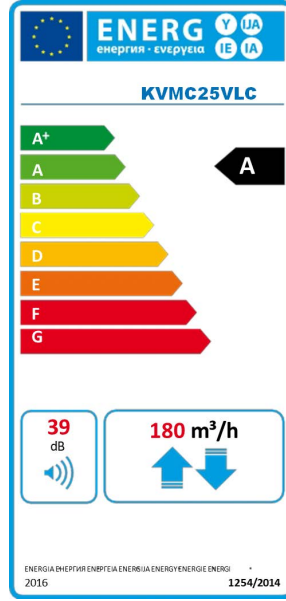
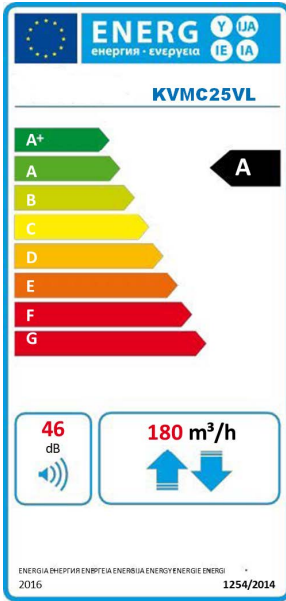

12. DECLARATION OF ENERGY PERFORMANCE

DECLARATION OF PERFORMANCE HEAT RECOVERY UNIT KVMC25VL

Supplier name or trade mark	VENTALOGIC			VENTALOGIC			VENTALOGIC		
Supplier Model Identifier and options installed	KVMC25VL+ 4BRF			KVMC25VL + RHRF / CO2RF			KVMC25VL+ RHRF / CO2RF local		
Reference climate	Temperate	Cold	Hot	Temperate	Cold	Hot	Temperate	Cold	Hot
SEC in [kWh/(m ² a)] per ogni tipo di clima (temperato, caldo, freddo)	-35,83	-76,93	-12,92	-38,59	-80,56	-14,55	-41,80	-84,92	-17,10
SEC Class	A	A+	E	A	A+	E	A	A+	E
Declared Typology	UVR-B Bidirectional			UVR-B Bidirectional			UVR-B Bidirectional		
Type of drive installed	Multi-speed drive			Variable speed			Variable speed		
Type of heat recovery	Recuperative			Recuperative			Recuperative		
Thermal efficiency ¹	81,1%			81,1%			81,1%		
Maximum flow rate in [m ³ /h] ²	180			180			180		
Maximum electric Power in [W]	60			60			60		
Sound Power Level (LWA) in [dB(A)] ³	46			46			46		
Reference flow rate [m ³ /h] ⁴	126			126			126		
Reference pressure difference in [Pa]	50			50			50		
SPI in [W/m ³ /h] ⁵	0,21			0,21			0,21		
Control factor and typology	1			0,85			0,65		
Declared maximum internal leakage [%] ⁶	1,2			1,2			1,2		
Declared maximum external leakage [%] ⁶	2,5			2,5			2,5		
Internet address for pre/dis-assembly instruction	www.ventalogic.com			www.ventalogic.com			www.ventalogic.com		

DECLARATION OF PERFORMANCE HEAT RECOVERY UNIT KVMC25VLC

Supplier name or trade mark	VENTALOGIC			VENTALOGIC			VENTALOGIC		
Supplier Model Identifier and options installed	KVMC25VLC + 4BRF			KVMC25VLC + RHRF / CO2RF			KVMC25VLC + RHRF / CO2RF local		
Reference climate	Temperate	Cold	Hot	Temperate	Cold	Hot	Temperate	Cold	Hot
SEC in [kWh/(m ² a)] per ogni tipo di clima (temperato, caldo, freddo)	-35,83	-76,93	-12,92	-38,59	-80,56	-14,55	-41,80	-84,92	-17,10
SEC Class	A	A+	E	A	A+	E	A	A+	E
Declared Typology	UVR-B Bidirectional			UVR-B Bidirectional			UVR-B Bidirectional		
Type of drive installed	Multi-speed drive			Variable speed			Variable speed		
Type of heat recovery	Recuperative			Recuperative			Recuperative		
Thermal efficiency ¹	81,1%			81,1%			81,1%		
Maximum flow rate in [m ³ /h] ²	180			180			180		
Maximum electric Power in [W]	60			60			60		
Sound Power Level (LWA) in [dB(A)] ³	39			39			39		
Reference flow rate [m ³ /h] ⁴	126			126			126		
Reference pressure difference in [Pa]	50			50			50		
SPI in [W/m ³ /h] ⁵	0,21			0,21			0,21		
Control factor and typology	1			0,85			0,65		
Declared maximum internal leakage [%] ⁶	1,2			1,2			1,2		
Declared maximum external leakage [%] ⁶	2,5			2,5			2,5		
Internet address for pre/dis-assembly instruction	www.ventalogic.com			www.ventalogic.com			www.ventalogic.com		

- 1: Efficiency according EN13141-7:2010 at reference flow at 50 Pa;
 - 2: Maximum flow at 100 Pa external pressure;
 - 3: Casing radiation at reference flow rate at 50 Pa external pressure;
 - 4: Reference flow rate is 70% of maximum flow at 50 Pa external pressure according EN13141-7:2010;
 - 5: According EN13141-7:2010 at reference flow rate;
 - 6: According EN13141-7:2010;
- SEC: Specific Energy Consumption.

DECLARATION OF PERFORMANCE HEAT RECOVERY UNIT KVMC25VLH

Supplier name or trade mark	VENTALOGIC			VENTALOGIC			VENTALOGIC		
Supplier Model Identifier and options installed	KVMC25VLH+ 4BRF			KVMC25VLH+ RHRF / CO2RF			KVMC25VLH + RHRF / CO2RF local		
Reference climate	Temperate	Cold	Hot	Temperate	Cold	Hot	Temperate	Cold	Hot
SEC in [kWh/(m ² a)] per ogni tipo di clima (temperato, caldo, freddo)	-32,31	-79,19	-9,46	-35,88	-76,82	-12,44	-40,03	-82,35	-15,78
SEC Class	A	A+	E	A	A+	E	A	A+	E
Declared Typology	UVR-B Bidirectional			UVR-B Bidirectional			UVR-B Bidirectional		
Type of drive installed	Multi-speed drive			Variable speed			Variable speed		
Type of heat recovery	Recuperative			Recuperative			Recuperative		
Thermal efficiency ¹	77,1%			77,1%			77,1%		
Maximum flow rate in [m ³ /h] ²	250			250			250		
Maximum electric Power in [W]	114			114			114		
Sound Power Level (LWA) in [dB(A)] ³	50			50			50		
Reference flow rate [m ³ /h] ⁴	175			175			175		
Reference pressure difference in [Pa]	50			50			50		
SPI in [W/m ³ /h] ⁵	0,28			0,28			0,28		
Control factor and typology	1			0,85			0,65		
Declared maximum internal leakage [%] ⁶	1,7			1,7			1,7		
Declared maximum external leakage [%] ⁶	1,5			1,5			1,5		
Internet address for pre/dis-assembly instruction	www.ventalogic.com			www.ventalogic.com			www.ventalogic.com		

DECLARATION OF PERFORMANCE HEAT RECOVERY UNIT KVMC25VLHC

Supplier name or trade mark	VENTALOGIC			VENTALOGIC			VENTALOGIC		
Supplier Model Identifier and options installed	KVMC25VLHC + 4BRF			KVMC25VLHC + RHRF / CO2RF			KVMC25VLHC + RHRF / CO2RF local		
Reference climate	Temperate	Cold	Hot	Temperate	Cold	Hot	Temperate	Cold	Hot
SEC in [kWh/(m ² a)] per ogni tipo di clima (temperato, caldo, freddo)	-32,31	-72,19	-9,46	-35,88	-76,82	-12,44	-40,03	-82,35	-15,78
SEC Class	A	A+	E	A	A+	E	A	A+	E
Declared Typology	UVR-B Bidirectional			UVR-B Bidirectional			UVR-B Bidirectional		
Type of drive installed	Multi-speed drive			Variable speed			Variable speed		
Type of heat recovery	Recuperative			Recuperative			Recuperative		
Thermal efficiency ¹	77,1%			77,1%			77,1%		
Maximum flow rate in [m ³ /h] ²	250			250			250		
Maximum electric Power in [W]	114			114			114		
Sound Power Level (LWA) in [dB(A)] ³	46			46			46		
Reference flow rate [m ³ /h] ⁴	175			175			175		
Reference pressure difference in [Pa]	50			50			50		
SPI in [W/m ³ /h] ⁵	0,28			0,28			0,28		
Control factor and typology	1			0,85			0,65		
Declared maximum internal leakage [%] ⁶	0,7			0,7			0,7		
Declared maximum external leakage [%] ⁶	1,5			1,5			1,5		
Internet address for pre/dis-assembly instruction	www.ventalogic.com			www.ventalogic.com			www.ventalogic.com		

- 1: Efficiency according EN13141-7:2010 at reference flow at 50 Pa;
 - 2: Maximum flow at 100 Pa external pressure;
 - 3: Casing radiation at reference flow rate at 50 Pa external pressure;
 - 4: Reference flow rate is 70% of maximum flow at 50 Pa external pressure according EN13141-7:2010;
 - 5: According EN13141-7:2010 at reference flow rate;
 - 6: According EN13141-7:2010;
- SEC: Specific Energy Consumption.

13. MODE OF INSTALLATION

Legend

- EX = exhaust air
- R = return
- FA = fresh air
- S = supply

KVMC25VL and KVMC25VLH

VERTICAL WALL INSTALLATION

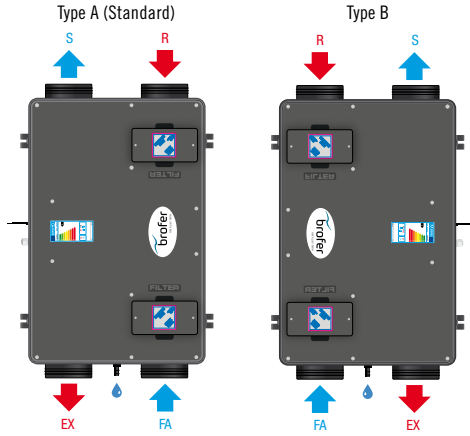

HORIZONTAL CEILING INSTALLATION

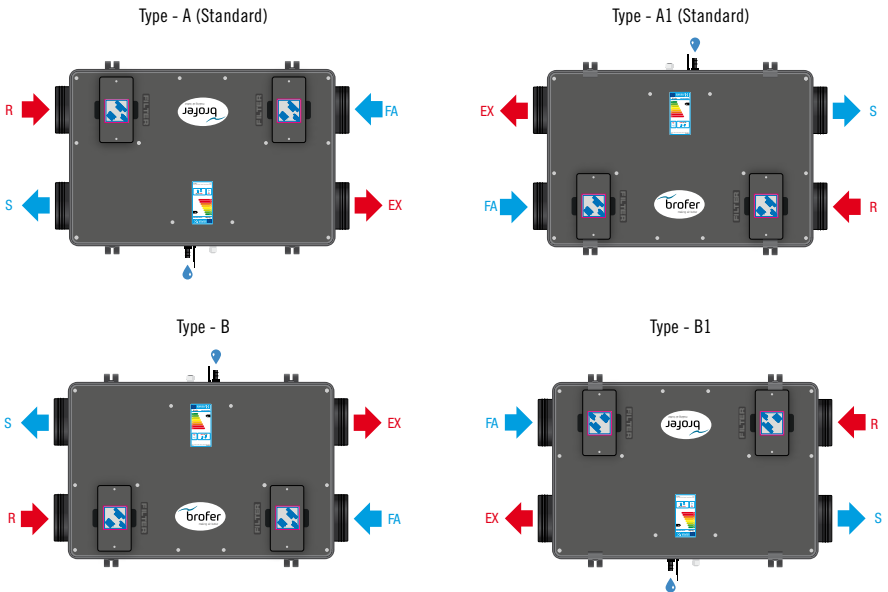

WALL CLAMPING (vertical installation)

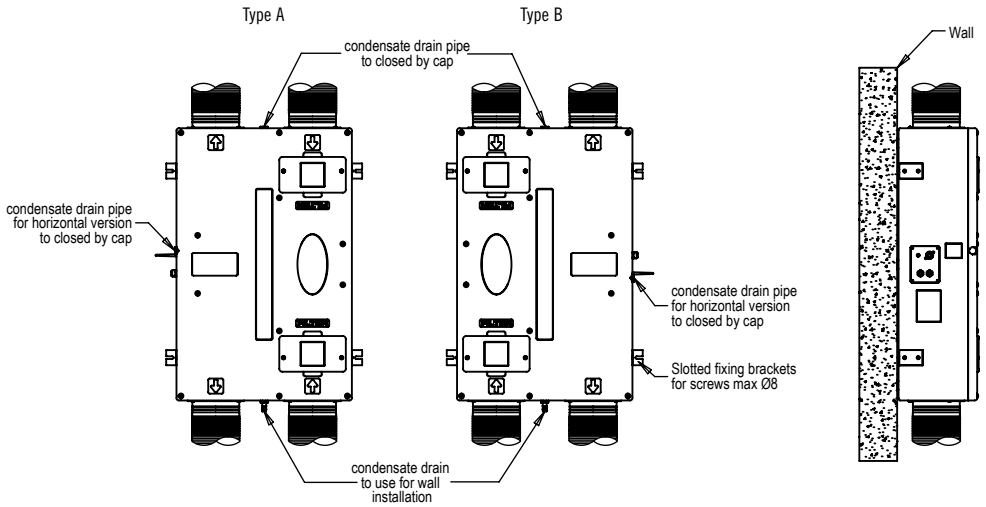

CEILING CLAMPING (horizontal installation)

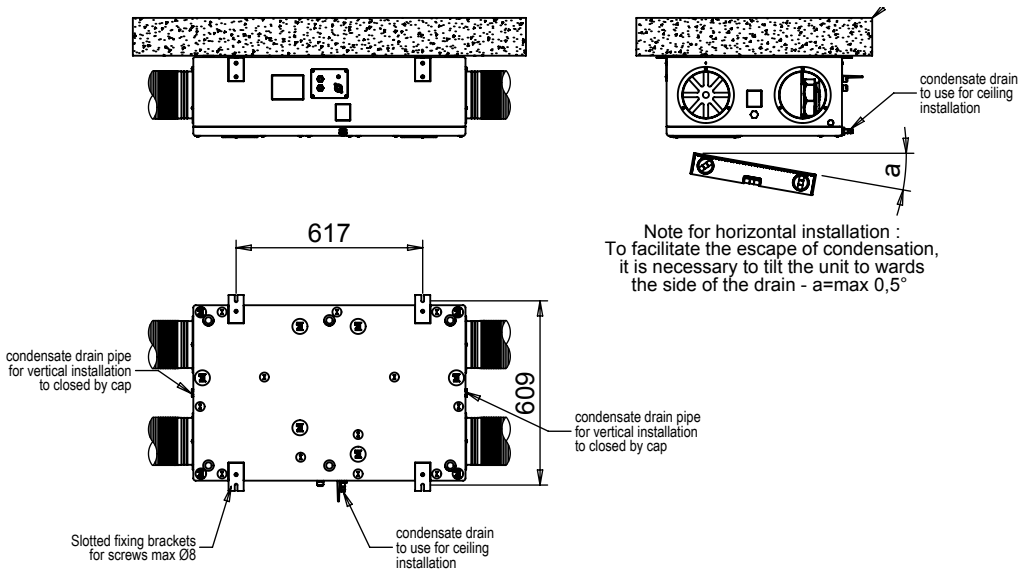

Use the fixing brackets for wall / ceiling mounting. Check the correct condensate drain pipe is used according to the installation position (horizontal or vertical). Securely cap off the unused condensate drain pipe.

Legend

EX = exhaust air

R = return

FA = fresh air

S = supply

KVMC25VLC and KVMC25VLHC

VERTICAL WALL INSTALLATION

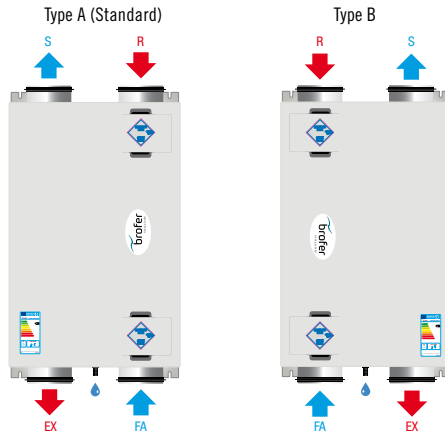

HORIZONTAL CEILING INSTALLATION

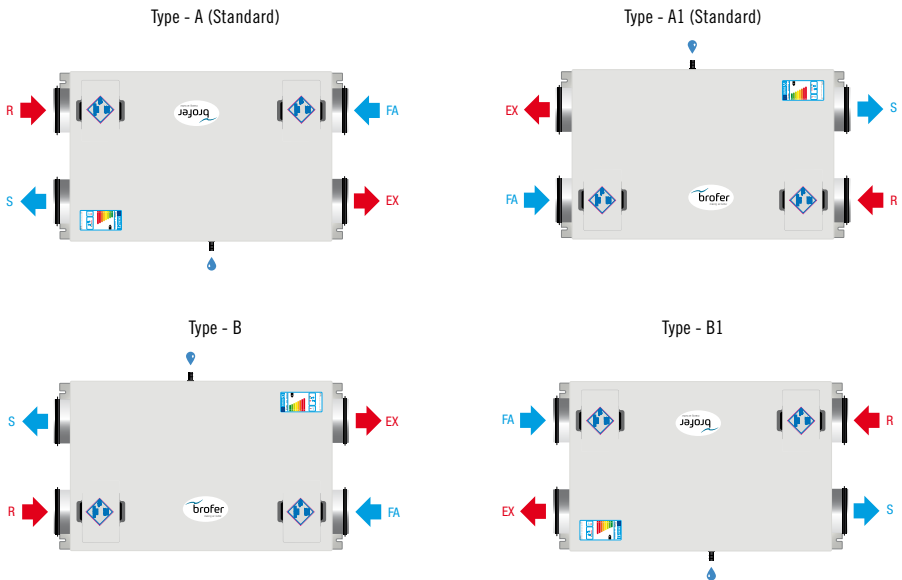

WALL CLAMPING (vertical installation)

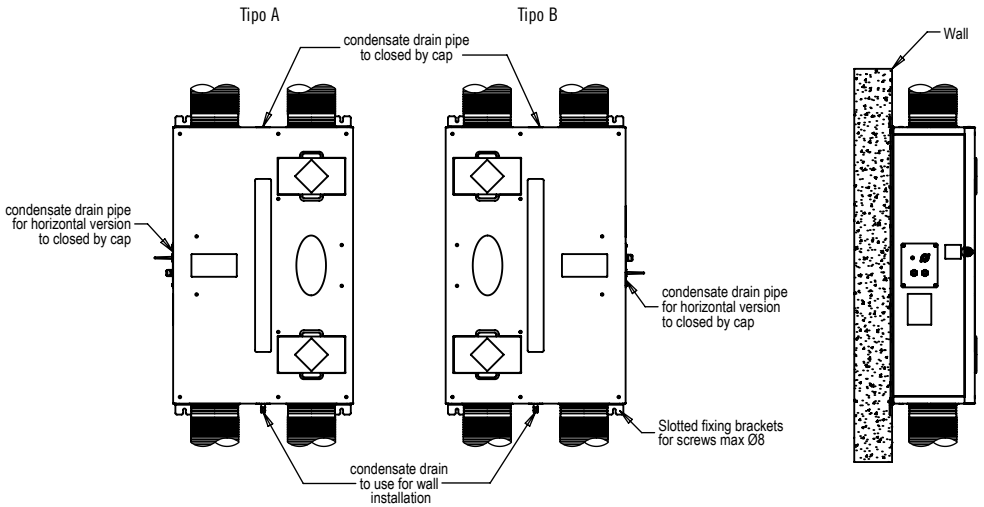

CEILING CLAMPING (horizontal installation)

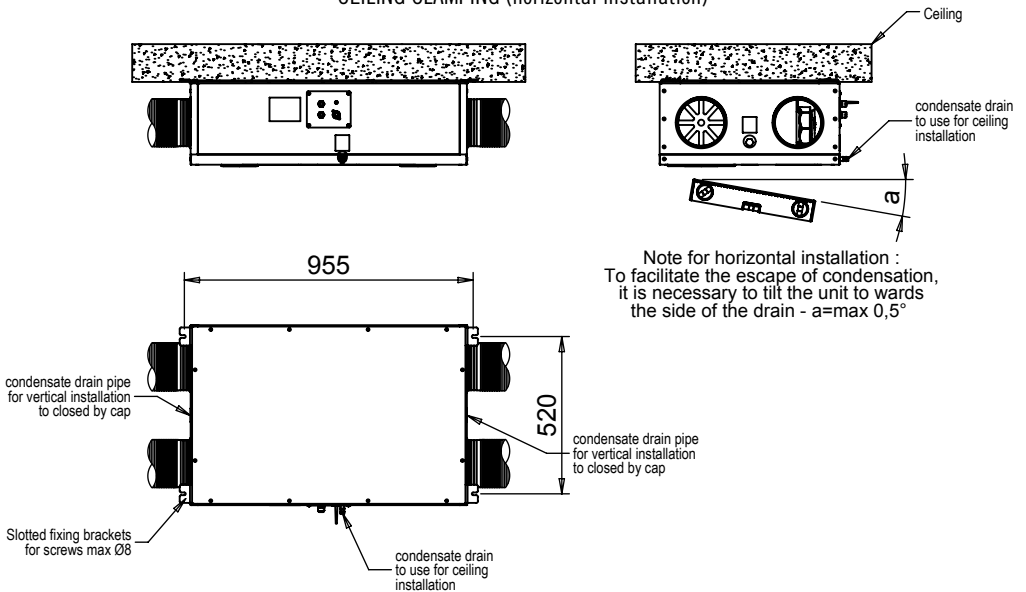

14. CONFIGURATION CHANGE FROM A (STANDARD) TO B

BYPASS FLOWS

The bypass system, with its motorized damper, provides, where appropriate, air directly from the outside without passing through the heat exchanger.

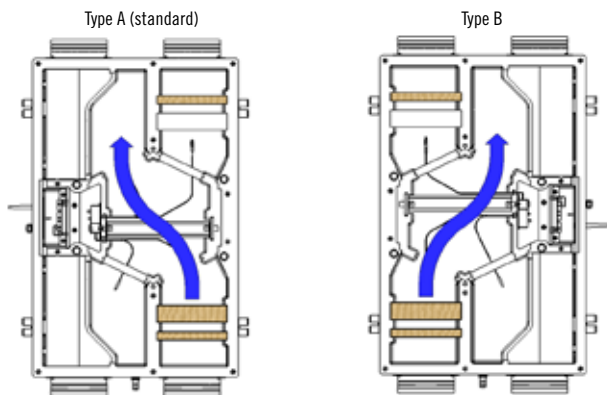

OPERATION SEQUENCE

Remove the screws fixing the front cover

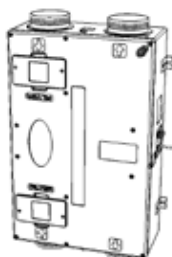

Move the F7 filter (if present) in the A position in the predisposition of the position B

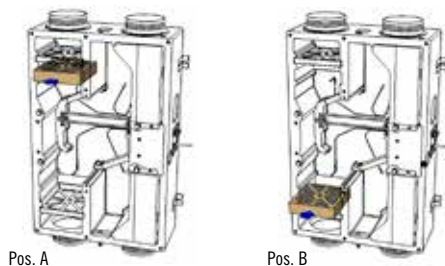

Remove the heat exchanger

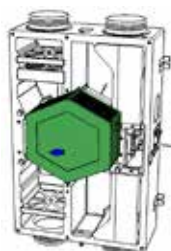

Extract of the system flow control Bypass bulkheads and insert them in the predisposition of the position B

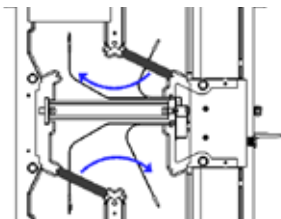

Insert the heat exchanger to the original location

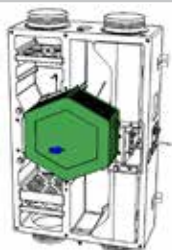

Remove the PCB cover

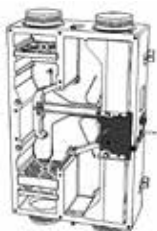

Pull the mounting plate to which the PCB is fixed

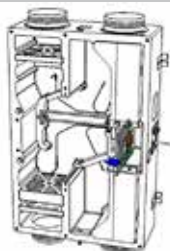

Reverse the plug and motor probes

See wiring diagrams

Insert the mounting plate to which is attached the PCB in its original location

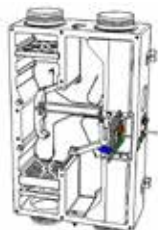

Replace the cover centering it through the four indentations. Hook the four side zippers.



15. ELECTRICAL CONNECTIONS

The nameplate indicates the type of power supply, the installed motor current, and the maximum current drawn by the fans. The electrical connections must be performed by qualified personnel in compliance with current standards.

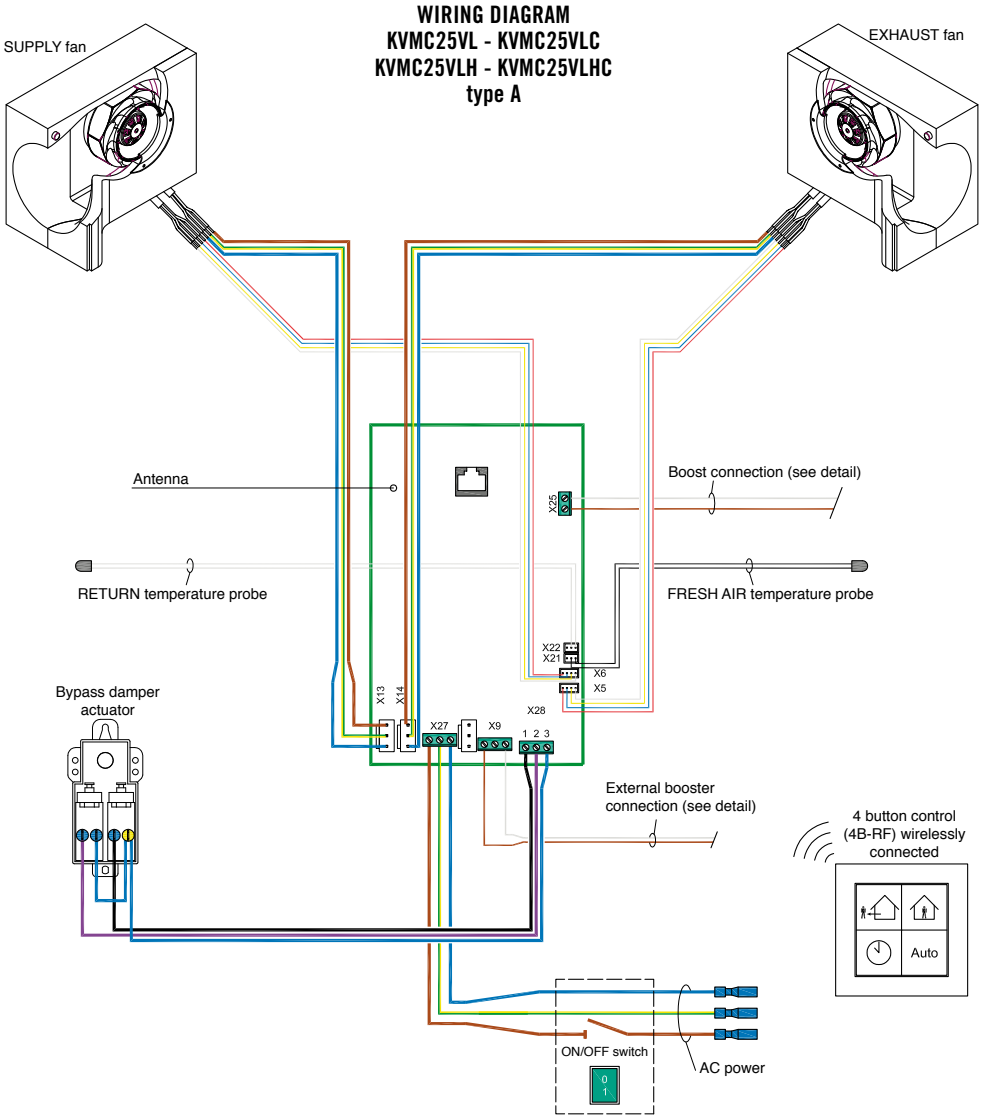

NOTE:

Protection against short circuits, overloads, voltage and direct contact, is the responsibility of the installer, as well as the verifying the rating of protective equipment.

Heat recovery unit applies for all units

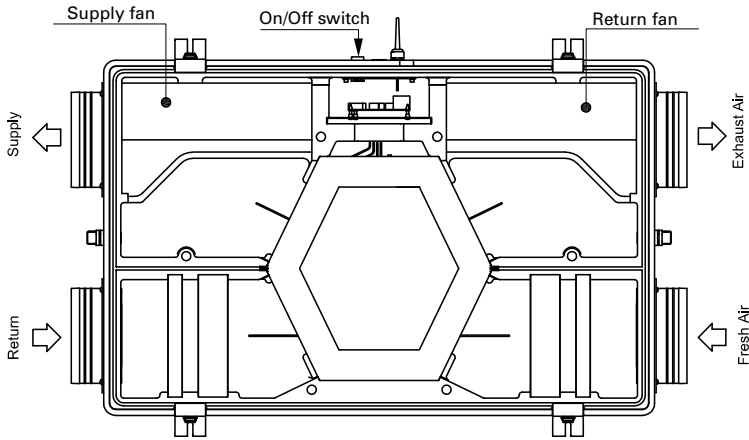

BOOST configuration detail



BOOSTER 3

Connection to the external switch.
Exhaust air fan in OFF position.
Supply fan at the speed set by 4B-RF

BOOSTER 1:

Connection to the external switch.
Medium-speed operation for both fans (HOME).

BOOSTER 2:

Connection to the external switch.
High speed operation for both fans (PARTY).

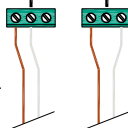

**WIRING DIAGRAM KVMC25VL
- KVMC25VLC KVMC25VLH -
KVMC25VLHC type B**

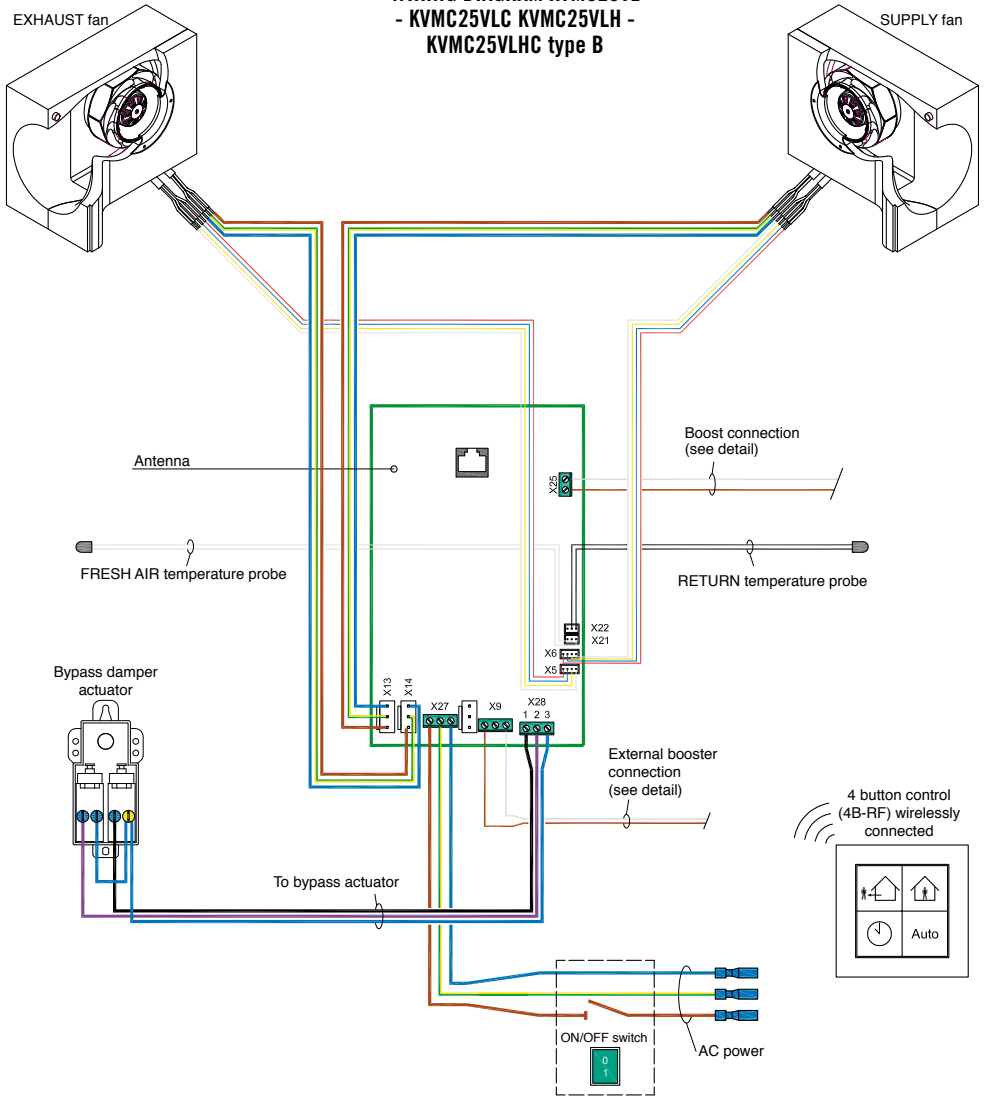

NOTE:

Protection against short circuits, overloads, voltage and direct contact, is the responsibility of the installer, as well as the verifying the rating of protective equipment.

Heat recovery unit applies for all units

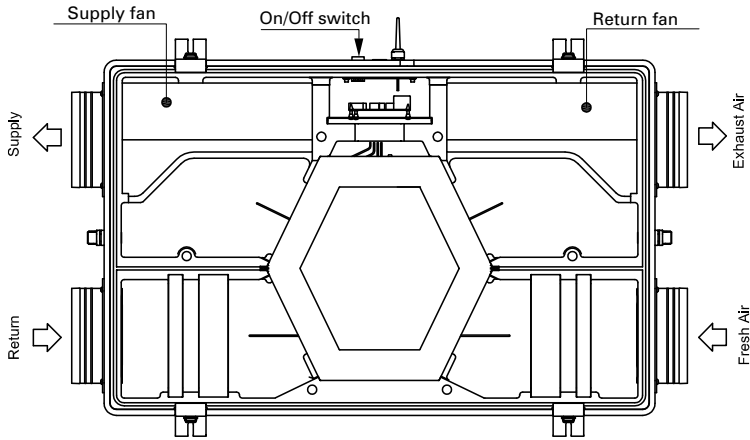

BOOST configuration detail



BOOSTER 3
Connection to the external switch.
Exhaust air fan in OFF position.
Supply fan at the speed set by 4B-RF

BOOSTER 1:
Connection to the external switch.
Medium-speed operation for both fans (HOME).

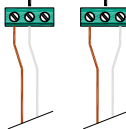

BOOSTER 2:
Connection to the external switch.
High speed operation for both fans (PARTY).

CHANGE ELECTRICAL WIRING FROM KVMC25VL / KVMC25VLC TYPE A TO KVMC25VL / KVMC25VLC TYPE B

1 Configuring connections to the PCB in the Type A mode

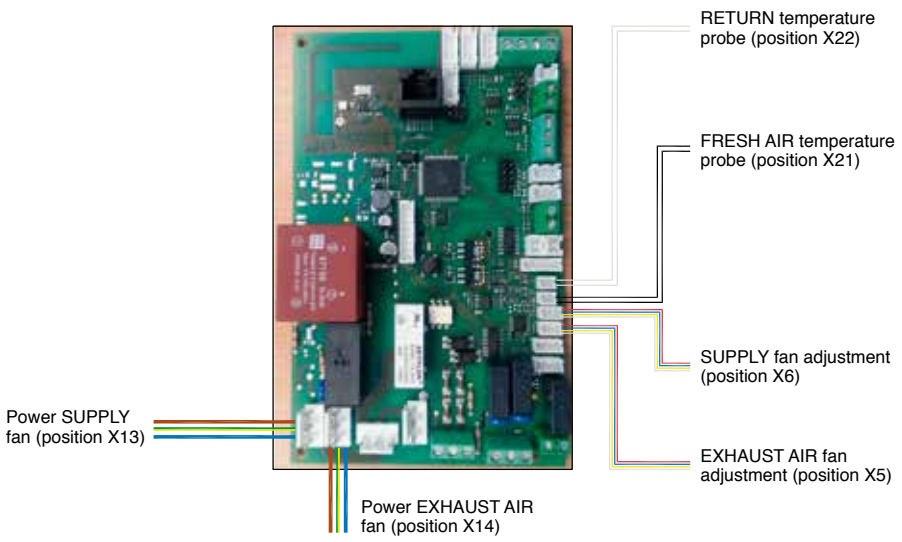

2 Editing connections to the PCB to switching from type A to type B mode

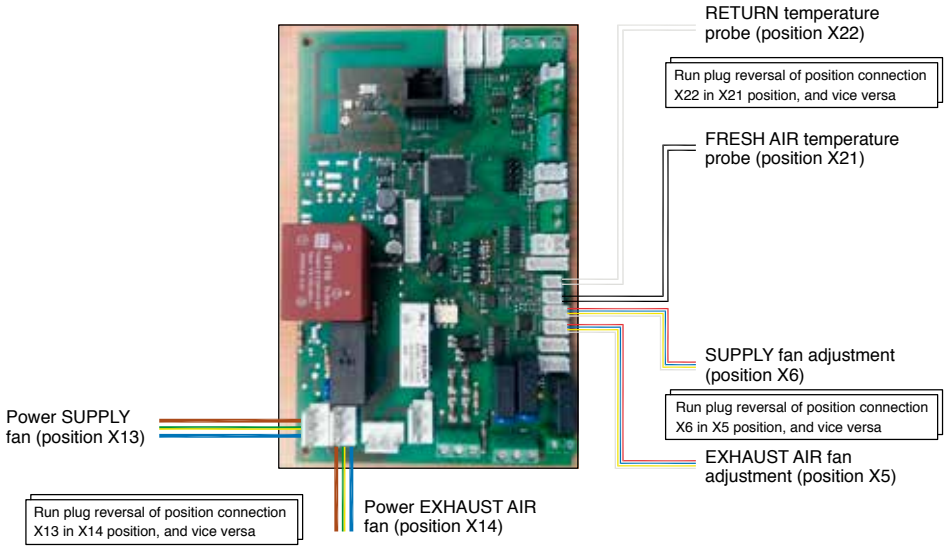

3

Configuring connections to the PCB in the Type B mode

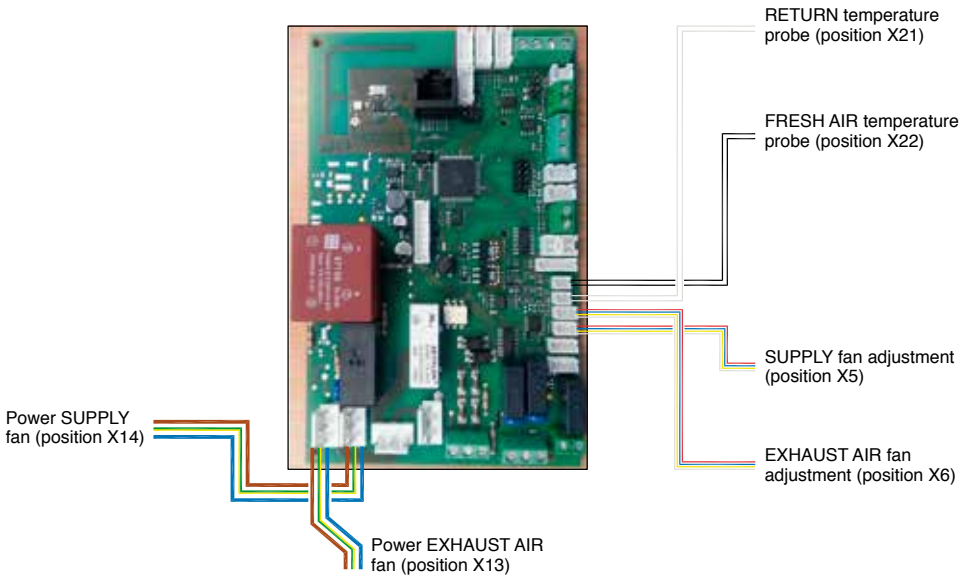

16. HYDRAULIC CONNECTIONS

The drain must be connected by means of a suitable siphon, ensuring that it is free and the rubber has not impediments and obstructions. The condensate drain system must be sized for proper operation; in all the sections of piping that constitute the drain connections to the sewer system, the water flow must be entrusted mainly to the weight of the liquid, without creating significant pressures or depressions and capable of altering the regular functioning of the flow.

Note:

if a direct connection is created with the external environment, air is sucked in, which can obstruct the flow of condensate. Avoid the use of a double siphon or that the siphon is laid forming many curves, as this obstructs the flow of condensate.

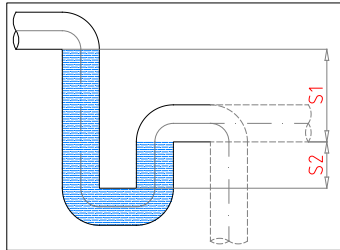

S1=50mm

S2=25mm

minimum compliance measures

17. AERAILIC CONNECTIONS

The duct connections should be made through circular ducts with the same diameters as those provided on the machine. The technical sizing of the ducts will still be carried out as function of the plant and of the pressure of the heat recovery unit. The machine is not equipped with anti-vibration joints internal joints on the attack so we recommend preparing these ducts in order to avoid any vibration.

18. VERIFICATION OF CURRENT CONSUMPTION

At full speed , check that the current consumption complies with the limits of the plate expressed in the case of abnormal consumption turn off the fan and contact our support department.

WARNINGS:

- **ALL WIRING AND ELECTRICAL COMPONENTS USED FOR THE INSTALLATION MUST COMPLY WITH THE REGULATIONS IN FORCE;**
- **THE POWER LINE MUST BE MADE IN ACCORDANCE WITH THE REGULATIONS IN FORCE;**
- **WIRING MUST BE DONE BY QUALIFIED TECHNICIANS ELECTRICIANS;**
- **THE CURRENT CONSUMPTION MUST COMPLY AS SET OUT IN THE DATA PLATE**

19. OPERATION AND USE

Before operating the machine, make sure that the discharges are free, that the air duct systems is free and, if present, appropriately dampers tuned.

20. ROUTINE MAINTENANCE

To enable smooth and steady performance of the machine and then a longer period of time it is advisable to carry out some simple routine maintenance. The frequency of interventions depends on the place and the quality of the air that is treated by the machine.

DISCONNECT THE POWER SUPPLY BEFORE ACCESSING ANY INSPECTION INSIDE THE MACHINE.

FANS: Check every 500 hours (approximately) of the cleaning operation of the fans and the presence of foreign bodies.

FILTERS: The control system automatically signals the need for filterre placement.

Also recommend the periodic inspection and cleaning of the heat exchanger always with an air jet to remove any impurities or deposited with the help of bactericidal products approved by health authorities.

21. DEFROST PROTECTION

The unit is provided by an automatic defrost system. Below the activation procedure:

When the fresh air temperature is $< 3\text{ }^{\circ}\text{C}$ the by-pass damper open and the supply fan turn off.

When the fresh air temperature is $> 5\text{ }^{\circ}\text{C}$ the by-pass damper close and the supply fan turn on.

22. FREE-COOLING

The unit is provided by an automatic free-cooling system with motorized by-pass damper of the heat exchanger. Below the activation procedure: When the room temperature is $> 23\text{ }^{\circ}\text{C}$ and the fresh air temperature is less than $3\text{ }^{\circ}\text{C}$ ($20\text{ }^{\circ}\text{C}$) the by-pass damper open. The by-pass damper anyway close when the fresh air temperature is $< 15\text{ }^{\circ}\text{C}$ or when the room temperature is $< 20\text{ }^{\circ}\text{C}$.

23. CONTROL SYSTEM

1 ABOUT THIS MANUAL

1.1 About the device

The VMN-02LM11 is a user control for a ventilation system. The device communicates information via wireless communications with the central control device.

1.2 How to use this manual

Make sure you have read and understood the manual before you install and/or use the device.

1.3 Original instructions

The original instructions for this manual have been written in English. Other language versions of this manual are a translation of the original instructions.

1.4 Admonitions

 **NOTA** - 'Note' is used to highlight additional information.

2 SAFETY

2.1 Directives

The device meets the following EC directives:

- EMC directive: 2014/30/UE
- Low voltage directive: 2014/35/UE
- RTTE directive: 2014/53/UE
- RoHS directive: 2011/65/UE
- WEEE directive: 2012/19/UE

2.2 Signs on the unit

 CE marking of conformity

 Use of the device may not be legal in every member state.

 Dispose according to European Community Directive 2012/19/UE (WEEE).

2.3 General safety instructions

The device is designed for indoor use only. Do not expose the device to rain or moisture, to avoid short circuit. Short circuit may cause fire or electric shock hazard. Operate the device between 0°C and 40°C.

For cleaning of the device use a soft damp cloth only. Never use any abrasive or chemical cleaner. Do not paint the device.

3 DESCRIPTION

3.1 Intended use

The device is designed for the purpose to set the level of ventilation through the fan speed, based on user input. Every other or further use is not in conformance with the intended use.





3.2 Working principle

The device communicates with the control device using wireless communications, in order to control the ventilation. When you press a button, the device sends this information to the ventilation system. The ventilation system processes this request and sends the resulting status back to the device. The device shows the resulting status on the LED.

3.2.1 Ventilation speeds and modes

The ventilation system runs in one of the following modes.

In each of these modes, the control device sets the ventilation system to a configured level of ventilation.

- Away mode:  Low fan speed
- Home mode:  Medium fan speed
- Timer mode:  High fan speed, for a restricted duration.
- Party mode:  High fan speed (default 100%)

The control device drives the fan based on the highest of values sent by the bound wireless sensor(s).

You can start the timer mode from this device for 30, 60 or 90 minutes.

4B-RF

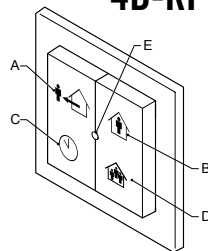

- A** Pulsante Away
- B** Pulsante Home
- C** Pulsante Timer
- D** Pulsante Party
- E** LED di stato

3.3 Segnali visivi

		Status LED
Startup		
Power up	Orange	1 flash
Status		
OK	Green	
Low battery	Orange	1 flash
Dirty filter		2 flashes
Fan error	Red	1 flash
Esito interazione		
Mode changed	Green	1 flash
Binding succeeded		2 flashes
Communication error	Red	1 flash

4 INSTALLATION

4.1 Preparation



NOTE

Do not place the device in a metal casing.

If not placing on a flush mounted wall box, prepare the wall:

1. Pull the buttons from the unit.

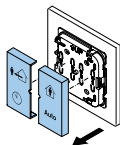

2. Loosen the clips and separate the unit from the mounting plate.

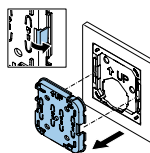

3. If using screws: prepare the wall, if needed. Use the mounting plate as a template.
4. If using tape:
 - a. Remove the foil from the double-sided tape.
 - b. Make sure that the surface is flat & clean.

4.2 Installation procedure

1. Place device / mounting plate.
2. If using screws: fasten the mounting plate using the screws.

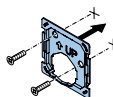

3. Place the device onto the mounting plate.

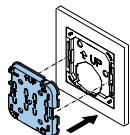

4. Place the buttons.

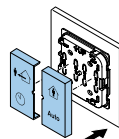

4.3 Commissioning

1. Make sure the control device is in binding mode.
2. Press and hold the two upper or two lower buttons.
The device tries to bind to the control device. It shows the result on the status LED.

5 Operation

(Vedere paragrafo 4 per maggiori informazioni visive)

1. Press the required button.

For button C:

press 1x for 30 minutes

press 2x for 60 minutes

press 3x for 90 minutes

The device shows the result on the status LED.

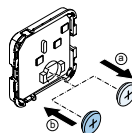

6 FILTER DIRTY RESET

To reset the filter dirty message, press and hold AWAY and PARTY for at least 4 seconds.

7 REPLACING THE BATTERY

(See section 4 for more visual instructions)

1. Remove the buttons from the unit.
2. Loosen the clips and separate the unit from the mounting plate.
3. Replacing the battery
 - a. Remove the old battery.
 - b. Place the new battery.The LED shortly shows orange.
4. Place the device onto the mounting plate.
5. Place the buttons.

8 TECHNICAL DATA

8.1 Dimensions

Overall dimensions (h x w x d): 84 x 84 x 15 mm
Weight: ± 125g

8.2 Ambient conditions

Operating Temperature Range: 0 to 40° C
Shipping & Storage Temperature Range: -20 to 55° C
Relative Humidity: 0-90%, non-condensing
Ingress protection (IEC60529): IP30

8.3 Battery specification

Type: CR2032
Battery lifetime: 6 years

8.4 Wireless connection specifications

Communication frequency: 868.3 MHz
Output power: at least 0 dBm.

You are not allowed to use the device outside of Europe.

24. DEVICE ERROR MESSAGES

The control board installed inside the heat recovery unit has multi-color LED. In the event of a fault, the corresponding fault code will be displayed with different color flashes. With the help of the colors assumed by the signaling LED it is possible to search for the meaning of the relative error message. Recognizing the sequence reproduced by the LED is useful for technical assistance in recognizing the type of fault in progress. Below is a summary table of possible errors.

Indication pattern	Function
	Binding mode is active (continuously green) ¹
	Normal mode (green LED flashes)
	Exhaust fan error (1 X red; 1 X orange)
	Supply fan error (1 X red; 2 X orange)
	Emergency temperature stop (2 X red; 1 X orange)
	X20 temperature sensor fault (2 X red; 2 X orange)
	X21 temperature sensor fault (2 X red; 3 X orange)
	X22 temperature sensor fault (2 X red; 4 X orange)
	X23 temperature sensor fault (2 X red; 5 X orange)
	RH sensor fault (3 X red; 3 X orange)
	Pressure sensor ONE (3 X red; 2 X orange)
	Pressure sensor TWO (3 X red; 1 X orange)
	Identification ² (orange LED flashes during 5 seconds)
	Filter dirty (1 X green; 1 X red)

¹ When the button is pressed the binding mode is ended.

² Identification message received.

When there is an error the fault status is shown, the priority is from tachometer to filter dirty with tachometer having the highest priority



VENTALOGIC

Ar puro Vida plena

DISTRIBUÍDO POR:

Lizgrácios, Lda.

Rua Central, 34

Casal dos Claros

2400-765 Amor Leiria

telef: 244 870 430

info@lizgracios.com

www.ventalogic.com