



Installation and Operation Manual



Residential Type Heat Recovery

KVMC 30 SH



Index

Warnings & Safety Informations.....	Page 15
Components.....	Page 16
Technical Data.....	Page 17
Performance Curve.....	Page 18
Unit Dimensions.....	Page 19
Service Space.....	Page 19
Installation	Page 20
Wiring Diagram.....	Page 22
Selection of Electrical Cable Cross-Section.....	Page 23
Control System.....	Page 24
Maintenance.....	Page 26

Warnings & Safety Information



PROHIBITED

- ◆ This unit has to be used under proper conditions according to its technical specification and design purpose. (Otherwise responsibility belongs to installer)
- ◆ Unauthorized personnel must not interfere in unit and/or must not use unoriginal spare parts. (Otherwise responsibility of failure that may occur belongs to installer)
- ◆ Do not install this product in a refrigerated warehouse, heated swimming pool or other location where temperature and humidity are significantly different. (Failure to heed this warning may result in electrical shock or malfunctioning.)
- ◆ Do not install this product where it will be directly exposed to rain. (Failure to heed this warning may result in electrical shock or malfunctioning.)
- ◆ Do not install this product in a location where acid, alkali or organic solvent vapors, paints or other toxic gases, gases containing corrosive components or high concentrations of oily smoke are present (Failure to heed this warning may result not only in malfunctioning but also fire, power leakage and electrical shock.)
- ◆ Do not use this product outside the range of its rated voltage and control capacity.



ATTENTION

- ◆ Install this product in an environment where the temperature ranges from 0 °C to +40 °C and the relative humidity is less than 80%. If condensation is expected to form, heat up the fresh outside air by a duct heater etc.
- ◆ Select an adequately sturdy position for installing the product and install it properly and securely.
- ◆ Use the designated electrical wires for the terminal board connections and connect the wires securely so that they will not be disconnected. (Failure to ensure proper connections may result in fire.)
- ◆ The outside ducts must be tilted at a gradient (1/30 or more) downwards toward the outdoor area from the main unit, and properly insulated. (The entry of rain water may cause power leaks, fire or damage to household property.)
- ◆ Gloves should be worn while installation. (Failure to heed this warning may result in injury.)
- ◆ A dedicated circuit breaker must be installed at the origin of mains power supply. This circuit breaker must be provided with a means for locking (lock and key).



- ◆ This product must not be disassembled under any circumstances. Only authorized repair technicians are qualified to conduct disassembly and repairs. (Failure to heed this warning may result in fire, electrical shock or injury.)



- ◆ Connect the product properly to the ground. (Malfunctioning or power leaks can cause electrical shock.)



- ◆ An isolator switch having minimum contact gap of 3 mm in all poles must be provided as a means of disconnecting the power supply.

Components

KVMC 30 VH Units

KVMC30VH units are designed for recovering part of the energy of the exhausted air in a ventilation system. The recovered energy is directly transferred to the supplied fresh air, that reduces the necessary load on the air conditioning system.

- 1 Control
- 2 Exhaust and Supply Air Filters
- 3 Damper Motor
- 4 Heat Recovery Exchanger
- 5 Casing
- 6 Exhaust and Supply Air Fans

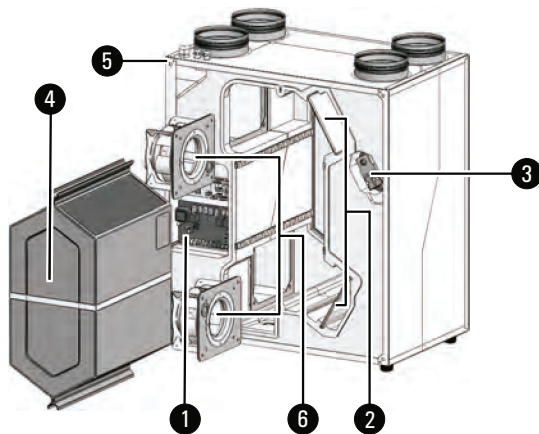

Technical Data

		KVMC 30 VH	
SEC ¹	Average	-33.77	A
	Warm	-9.84	F
	Cold	-70.94	A+
Typology		Bidirectional	
Type of drive		Variable speed	
Heat recovery system		Recuperative	
Thermal efficiency	%	85.8	
Maximum flow rate (@100Pa)	m ³ /h	220	
Electrical power input at maximum flow	W	112	
Sound power level at reference flow rate	L _{wa}	57.4	
Reference flow rate	m ³ /s	0.043	
Reference pressure difference	Pa	50	
SPI	W(m ³ /h)	0.328	
Control factor and typology		1/Manual	
Declared leakage rates		0.3-Internal	
		0.4-External	
Mixing rate	%	0	
Internet address		www.ventalogic.com	
Air flow rate sensivity		N/R	
Indoor/outdoor air tightness		N/R	
AEC ²	Average	10.7	
	Warm	10.3	
	Cold	16.1	
AHS ³	Average	44.5	
	Warm	20.1	
	Cold	87	

¹ Specific Energy Consumption [kWh/(m².a)]

² Annual Electricity Consumption [kWh/a electric per year]

³ Annual Heating Saved [kWh fuel gross calorific value per year]

Performance Curve

KVMC 30 VH

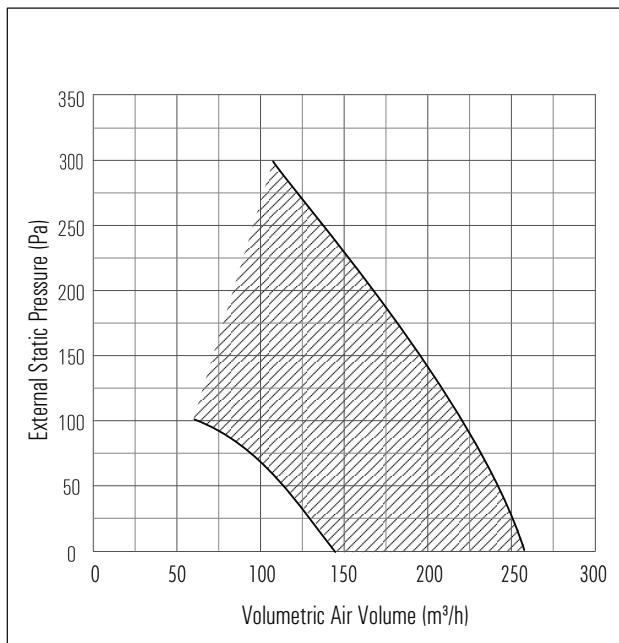

Unit Dimensions

KVMC 30 VH Units

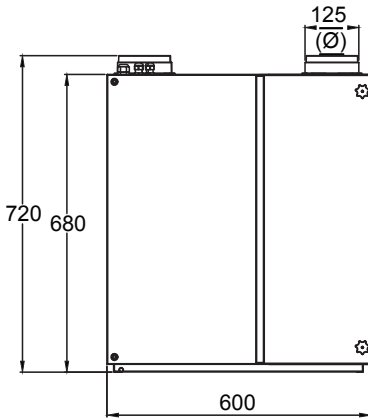

*View from front

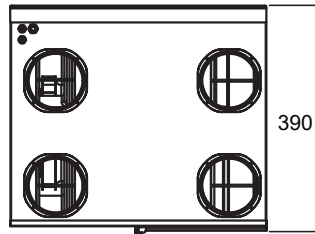

*Bovenaanzicht

* Unit weight is 37 kg

* All measurement values are mm.

Service Space

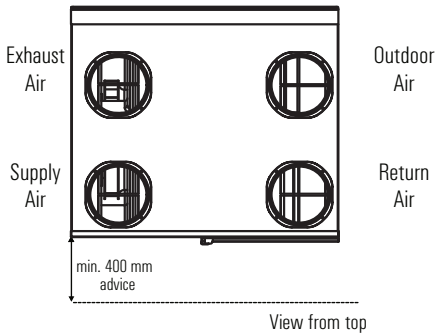

* A clear space of 400 mm must be provided in front of the unit for service.

* Drain pipe must be installed

Installation

Wall Mounting

1. Mount the wall bracket with screw (3 pcs $\text{\O}5 \times 40$ screw and fixing plug.)
2. Make sure that the unit is properly fit on the bracket.
3. For set the level of unit use screw on figure 3.

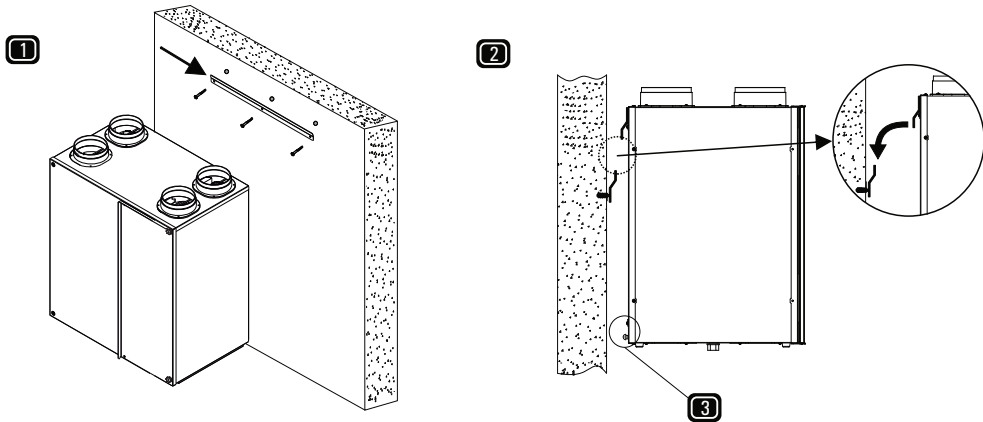

Floor Mounting

Unit can be placed directly on level ground.

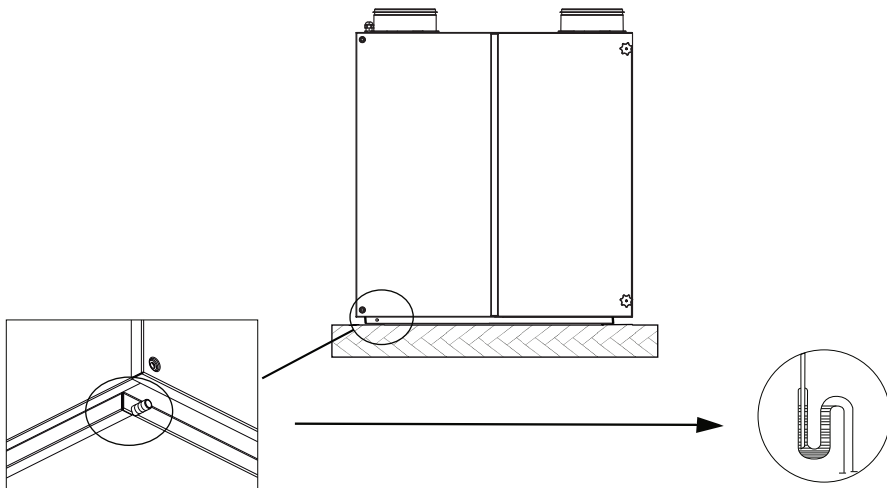

Installation

Discharge Condensate Installation

Moisture condensed water should be drained out of the unit, to prevent water damage in heat recovery unit and ductwork system. Following precautions should be observed :

1. Condensate pipe connections to main drainage line should not be less than the diameter of the drainage outlet connection (Not less than a diameter of 10 mm).
2. A union or pipe coupling should be fitted at the pipe connections to permit easy disconnection to clean any dirty sediments.
3. The connection drain pipe shall have a diameter of at least 10 mm and a sufficient slope; under no circumstance may the drain pipe be connected directly.

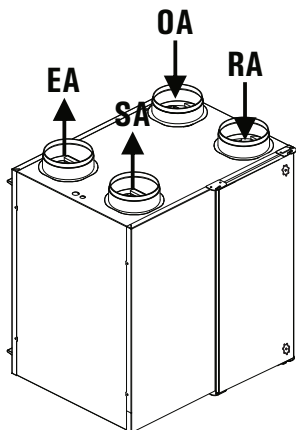
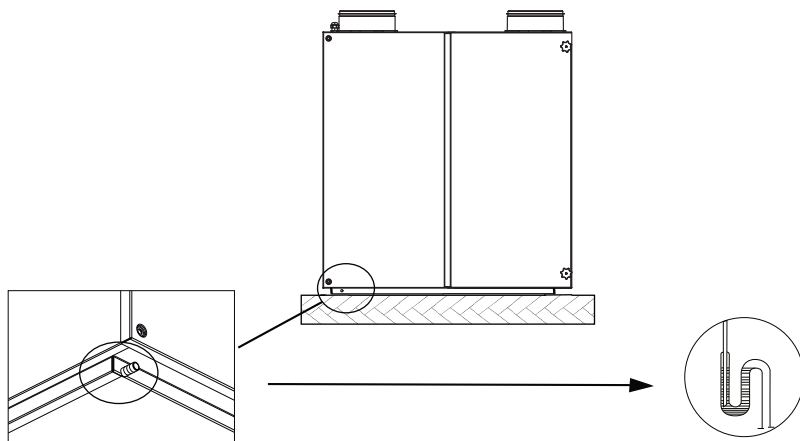

EA ___ Exhaust Air
SA ___ Supply Air
OA ___ Outdoor Air
RA ___ Return Air

Wiring Diagram

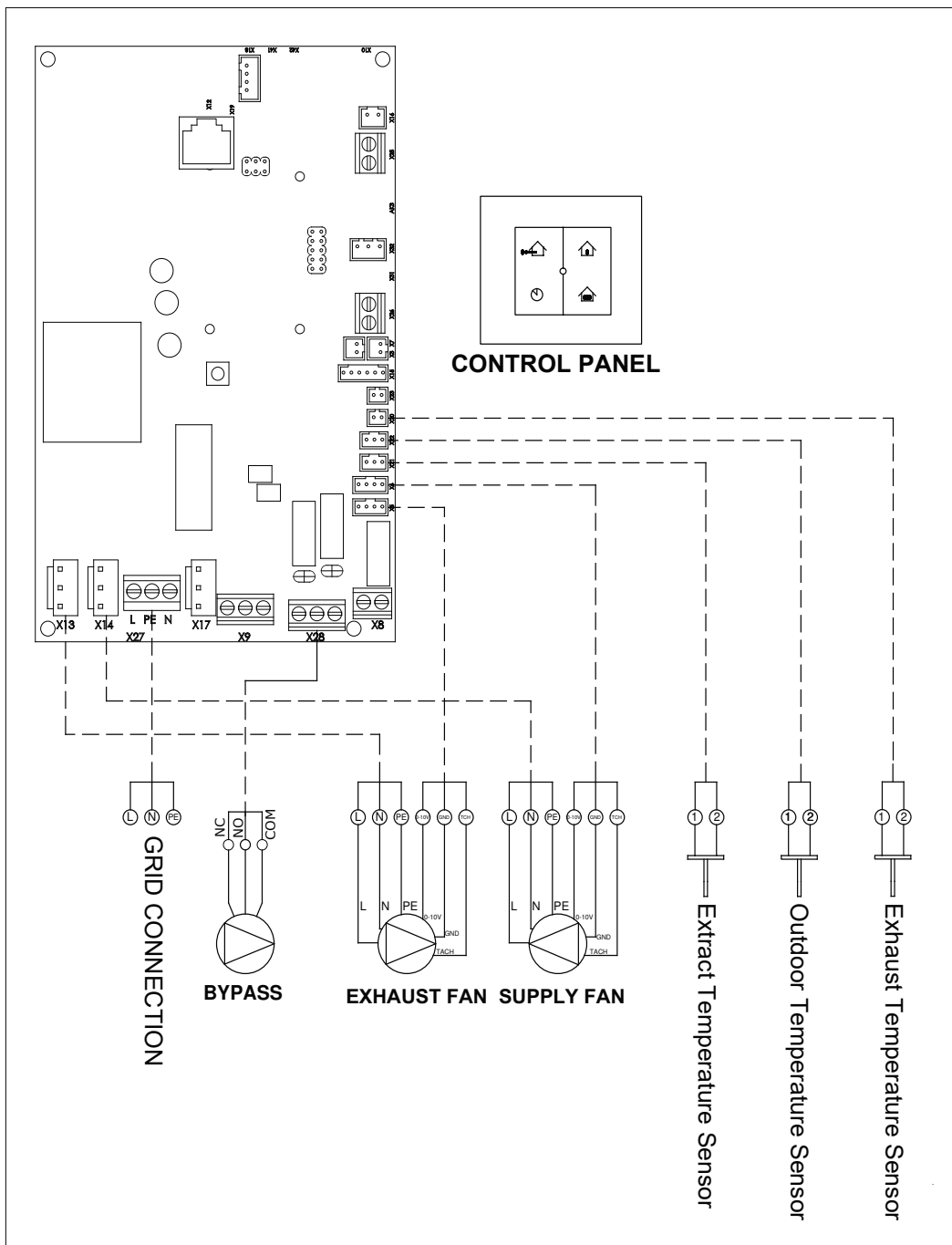

Selection of Electrical Cable Cross-Section

Unit Model	Unit Voltage (V)	Unit Power Input (kW)	Current (A)	Fuse (A)	Cable Cross-Section(mm ²) for 50M and PF=0.8
KVMC30VH	230	0.086	0.5	0.5	1.5

Cable Cross-Section Formulas

1

$$I_{\text{current}} = \frac{P}{U \cdot \cos\phi}$$

$$I_{\text{cable}} > I_{\text{current}}$$

2

$$\%e = \frac{100 \cdot P \cdot L}{k \cdot S \cdot U^2}, S = \frac{100 \cdot P \cdot L}{k \cdot \%e \cdot U^2}$$

$$\%e = \%3$$

3

$$I_{\text{cable}} > I_{\text{fuse}} \geq I_{\text{current}}$$

$$\text{Cable Cross-Section } S = \text{Max}(S1, S2, S3, 1.5 \text{mm}^2)$$

P : Power

I : Current

U : Voltage

S : Conductor cross section

k : Conductor coefficient

L : Conductor length

%e: The voltage drop

Example of Cable Cross-Section Calculation

$$P : 0,169 \text{ kW}$$

$$L : 50\text{m}$$

$$U : 230\text{V}$$

$$\%e : \%3$$

$$PF : \cos\phi : 0,8$$

$$k : 56\text{m} / \Omega$$

1

$$I_{\text{current}} = \frac{166 \text{ W}}{230 \cdot 0,8} = 0.9 \text{ A}$$

The cable will be used, is selected from the cable cross-section table so that the equivalent ampere value in the table should be higher than calculated "I_{current}" value.

$$S1 = 0.5 \text{ mm}^2$$

2

$$\%e = \%3$$

$$S = \frac{100 \cdot 166 \cdot 50}{56.3 \cdot 230^2} = 0.09 \text{ mm}^2$$

$$S2 \geq 0.09 \text{ mm}^2 \geq 0.5 \text{ mm}^2$$

$$S2 = 0.5 \text{ mm}^2$$

3

$$I_{\text{cable}} > I_{\text{fuse}} \geq I_{\text{current}}$$

$$I_{\text{cable}} > 0.5\text{A} \geq 0.09\text{A}$$

"I_{fuse}" which will be higher than "I_{current}", is selected.

The cable will be used, is selected from the cable cross-section table so that the equivalent ampere value in the table should be higher than selected "I_{fuse}" value.

$$I_{\text{cable}} = 12\text{A}$$

$$S3 = 0.5 \text{ mm}^2$$

$$\text{Cable cross-section } S = \text{Max}(S1, S2, S3, 1.5 \text{mm}^2)$$

$$S = \text{Max}(0.5, 0.5, 0.5, 1.5)$$

$$S = 1.5 \text{ mm}^2$$

Control System

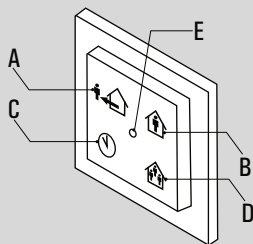

- A: Away button
- B: Home button
- C: Timer button
- D: Boost button
- E: Status LED

1 About this manual

1.1 About the device

The 4B-RF is a user control for a ventilation system.

The device communicates information via wireless communications with the central control device.

1.2 How to use this manual

Make sure you have read and understood the manual before you install and/or use the device.

1.3 Original instructions

The original instructions for this manual have been written in English. Other language versions of this manual are a translation of the original instructions.

1.4 Admonitions

NOTE 'Note' is used to highlight additional information.

2 Safety

2.1 Directives

The device meets the following EC directives:

- EMC directive: 2004/108/EC
- Low voltage directive: 2006/95/EC
- RTTE directive: 1999/5/EC
- RoHS directive: 2002/95/EC
- WEEE directive: 2002/96/EC

2.2 Signs on the unit



CE marking of conformity



Use of the device may not be legal in every member state.



Dispose according to European Community Directive 2002/96/EC (WEEE).

2.3 General safety instructions

The device is designed for indoor use only. Do not expose the device to rain or moisture, to avoid short circuit. Short circuit may cause fire or electric shock hazard. Operate the device between 0°C and 40°C. For cleaning of the device use a soft damp cloth only. Never use any abrasive or chemical cleaner. Do not paint the device.

3 Description

3.1 Intended use

The device is designed for the purpose to set the level of ventilation through the fan speed, based on user input. Every other or further use is not in conformance with the intended use.





3.2 Working principle

The device communicates with the control device using wireless communications, in order to control the ventilation.

When you press a button, the device sends this information to the ventilation system. The ventilation system processes this request and sends the resulting status back to the device. The device shows the resulting status on the LED.

3.2.1 Ventilation speeds and modes

The ventilation system runs in one of the following modes. In each of these modes, the control device sets the ventilation system to a configured level of ventilation.

- ▶ **Away mode:**  Low fan speed
- ▶ **Home mode:**  Medium fan speed
- ▶ **Timer mode:**  High fan speed, for a restricted duration.
- ▶ **Party mode:**  High fan speed (default 100%)

The control device drives the fan based on the highest of values sent by the bound wireless sensor(s).

You can start the timer mode from this device for 30, 60 or 90 minutes.

3.3 Visual signals

Startup	Status LED
Power up	Orange 1 flash
Status	
OK	Green
Low battery	Orange 1 flash
Dirty filter	Orange 2 flashes
Fan error	Red 2 flashes
Interaction response	
Mode changed	Green 1 flash
Binding succeeded	Green 2 flashes
Communication error	Red 1 flash

Control System

4 Installation

4.1 Preparation

NOTE Do not place the device in a metal casing.

If not placing on a flush mounted wall box, prepare the wall:

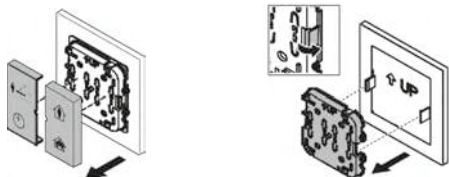

1. Pull the buttons from the unit
2. Loosen the clips and separate the unit from the mounting plate.

4.2 Installation procedure

1 Place device / mounting plate

2 If using screws: fasten the mounting plate using the screws.

3 Place the device onto the mounting plate.

4 Place the buttons.

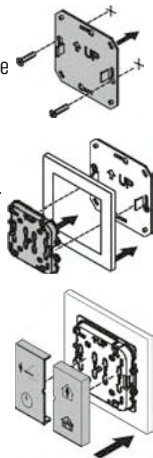

4.3 Commissioning

1 Make sure the control device is in binding mode.

2 Press and hold the two upper or two lower buttons.

The device tries to bind to the control device.
It shows the result on the status LED.

5 Operation

1. Press the required button.

For button C:

press 1x for 30 minutes

press 2x for 60 minutes

press 3x for 90 minutes

The device shows the result on the status LED.

6 Filter dirty reset

To reset the filter dirty message, press and hold AWAY and PARTY for at least 4 seconds.

7 Replacing the battery

(See section 4 for more visual instructions)

1 Remove the buttons from the unit.

2 Loosen the clips and separate the unit from the mounting plate.

3 Replacing the battery

a Remove the old battery.

b Place the new battery.

The LED shortly shows orange.

4 Place the device onto the mounting plate.

5 Place the buttons.

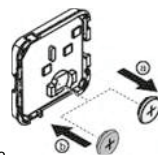

8 Technical data

8.1 Dimensions

Overall dimensions (h x w x d): 84 x 84 x 15 mm

Weight: ± 125g

8.2 Ambient conditions

Operating Temperature Range: 0 to 40 °C

Shipping & Storage Temperature

Range: -20 to 55 °C

Relative Humidity: 0 - 90%, non-condensing

Ingress protection (IEC60529): IP30

8.3 Battery specification

Type: CR2032

Battery lifetime: 6 years

8.4 Wireless connection specifications

Communication frequency: 868.3 Mhz

Output power: at least 0 dBm.

Maintenance

- ◆ TURN OFF all the power switches before the maintenance is performed.
- ◆ Do not operate the system without the air filter to protect the components of the unit against being clogged.
- ◆ Clean up the air filter every 3 months. Filters should be replaced every 6 months.
- ◆ Clean up the heat exchanger every 2 years.

Air Filter Cleaning

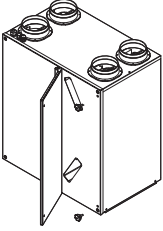

Open the service door.

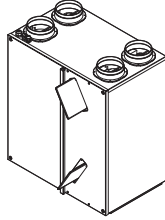

Take out the filters.

Step 1: Open the service cover and then remove the filters.

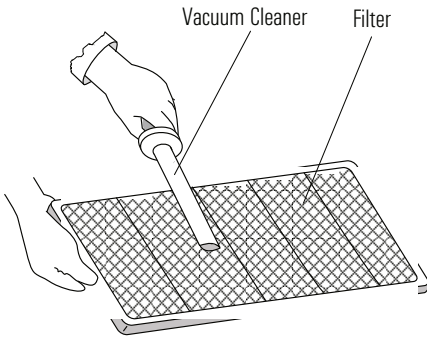

Step 2: Use a vacuum cleaner to suck up the dust from the air filter. If necessary, use warm water with addition a house detergent to remove the persistent dirt. Leave to dry after cleaning the air filter.

Note: If F7 class filter is used, when filter gets dirty, do not clean! F7 class filters should be replaced if it is dirty.

Heat Exchanger Cleaning

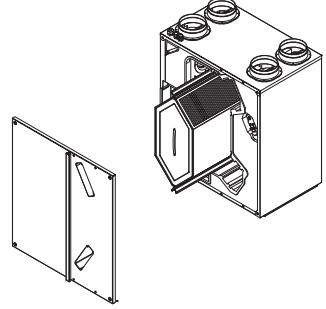

Step 1: Remove the front cover plate, then remove the exhaust air temperature sensor which is located inside heat exchanger at exhaust side.

Step 2: Remove the heat exchanger out from the main unit.

Note: The maximum weight of heat exchanger is 5.5 kg.

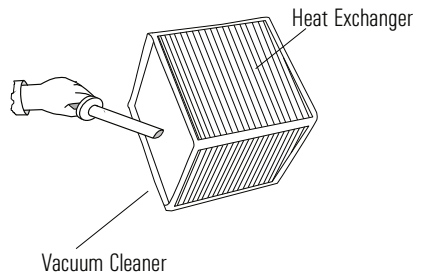

Step 3: No cleaning with fluids (including water); only careful dust removal from air intake surfaces with a household vacuum cleaner.



VENTALOGIC

Ar puro Vida plena

DISTRIBUÍDO POR:

Lizgrácios, Lda.

Rua Central, 34

Casal dos Claros

2400-765 Amor Leiria

telef: 244 870 430

info@lizgracios.com

www.ventalogic.com